

**HAWK**

www.cleanandcoat.co.za

# Clean and coat news

Durban (Head Office): (031) 205-4313, Johannesburg: (011) 974-4662, George: (044) 874-2401, Port Elizabeth: (041) 451-4332, Cape Town: (021) 9763-073

Issue 83 - September 2005

Hawk Clean and Coat is a division of 

## Air operated double diaphragm pump - big performance - miniature size

The G56 pump is manufactured from corrosion resistant polypropylene which is capable of handling a wide range of chemicals. The diaphragms are made from Santoprene. With inlet air pressure of up to 6.9bars and at maximum flow of 26,5 l/min, this is an incredibly versatile pump. When the outlet is closed, the pump immediately stops but it also has a patented shuttle valve which cannot stall. It has leak resistant radial seals and a large exhaust muffler resulting in quiet operation.

Applications for this pump include chemical transfer, liquid dispensing, pumping of flammable liquids and a multitude of food applications.



## Dimensional Drawing

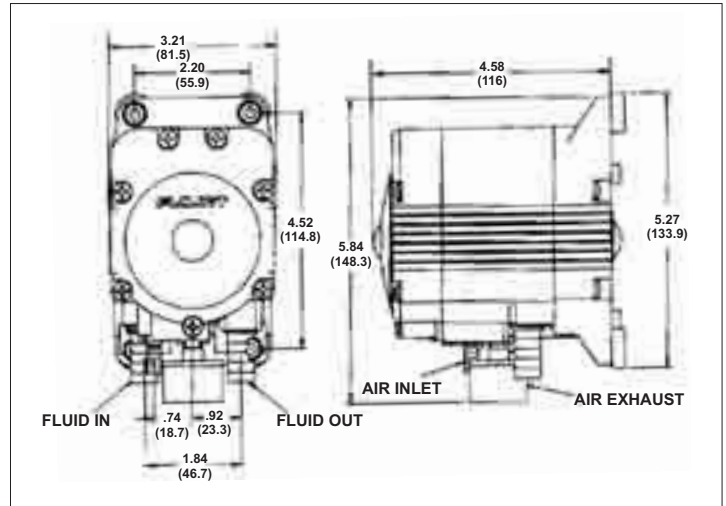

## The new VS28 pump protection valve

The VS28 valve is designed to protect pumps by preventing pressure spikes at the unloader while the machine is in operation. It can be fitted on the pump head before the unloader valve or the regulator valve in order to achieve optimal protection of the pump. In case of a pressure spike, the VS28 valve intervenes by opening to by-pass.



## Hawk Pneumatic 4:1 Pump

The 4:1 ratio transfer pump is used for volume transfer of liquids and can be manufactured in stainless steel for special liquids. The pump is robust and can be stalled without damage. It comes complete with air line lubricator and a pump "positioner" for securing the pump to a 210 litre drum. With an air supply of, say, 7 bar, the pump delivers 28 bar and can transfer up to 50 l/min.



*"Your life is like a mirror, if you face it smiling, it smiles right back"*

## Versatile, durable and affordable high density foaming solutions



The compressed air operated foaming unit is specially designed for cleaning applications where it is necessary to apply thick volumes of foam. The unit is pressurised by a compressor (not included) and then it is wheeled around on the handy trolley to areas where it is required. The compressed air performs two functions. Firstly it pressurises the tank enabling the operator to dispense the chemical, and secondly it aerates the chemical turning it into a thick foam that is able to hang on vertical surfaces for longer periods of time, thereby increasing its effectiveness. The unit which was designed by Monitor Distributors has been extremely effective in the pig and poultry industries where foaming and disinfecting is crucial to productivity. It is also useful for de-greasing applications.

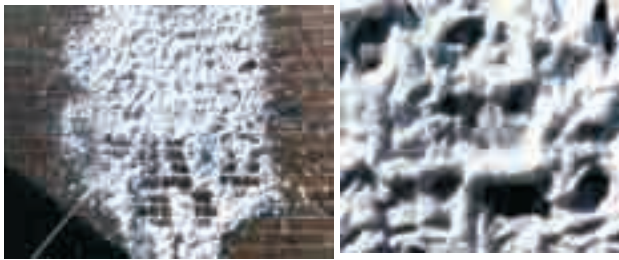

Apply high density foam to large areas quickly.

Technical Data:

<b>Model:</b>	5HF-FOAMER
<b>Tank capacity:</b>	17 Lt
<b>Tank material:</b>	Stainless steel
<b>Inlet air pressure:</b>	2 - 3 bar
<b>Max. tank pressure:</b>	12 bar



## Unique Guarantee

Precision engineering and the use of high quality materials have enabled Hawk in South Africa to give a comprehensive Guarantee to cover their products. A full one year's warranty covers the workmanship and materials against defects, while they are also covered by a unique spares guarantee. Should the required Hawk pump or accessory spare part not be available within 24 hours because of a out-of-stock situation, they will be airfreighted from the factory, and fitted, free of charge.



[www.cleanandcoat.co.za](http://www.cleanandcoat.co.za)